



LTB3421 1250 Mb/sec PX-20 P2MP ONU

Burst Mode SFF E-PON Transceiver with SD

The LTB3421 E-PON ONU transceiver module has been designed for low cost point to multi point (P2MP) Fiber to the Home, Business or Curb (FTTX) systems employing high-speed burst mode TDM receivers/transmitters in 1250 Mb/sec symmetrical duplex data links. The device is based on the IEEE 802.3ah 1000BASE PX20 specification for bi-directional communications over a single fiber and incorporates a high performance 1310 nm burst mode F-P transmitter and 1490 nm CW mode P-I-N receiver. It is capable of serving up to 16 subscribers in advanced TDM P2MP FTTH equipment over distances of up to 20 km. The LVTTTL compatible Tx Disable feature controls the laser transmitter and the LVTTTL compatible Rx Signal Loss feature monitors the optical input signal. The industry standard 2x5 small form factor (SFF) package incorporates a pigtail fiber with SC/APC or SC/PC connector, and is fabricated with a rugged die cast metal housing and cage assembly and operates over the extended temperature range from -40 to +85 degrees Centigrade.

Applications

- Gigabit Ethernet Access Networks
- Fiber to the Home, Curb, Office (FTTx)
- Point to Multi Point Service (P2MP)
 - Up to 20 km Reach (16:1 Split)
 - Up to 10 km Reach (32:1 Split)
- 1310 nm F-P Burst Mode Laser
- 1490 nm CW Mode PIN/TIA Receiver
- IEEE 802.3ah Compliant
- Single 3.3 Volt DC supply
- Low Power Consumption
- 2x5 SFF Package Outline
- Single Fiber, Full Duplex Operation
- Pigtail Optical Interface with Optional Connector
- Operating Temperature Range:
 - Commercial: 0 to 70 °C
 - Extended: -10 to 80° C
 - Industrial: -40 to +85 ° C

Features

- Dual Wavelength Bi-Directional Tx/Rx
- Sub-50 Nanosecond Burst Mode Tx
- 1250 Mb/s Symmetrical Tx/Rx Data Rate

- Data and Control Interfaces
 - Tx_Data LVPECL Differential
 - Rx_Data LVPECL Differential
 - Tx_DIS LVTTTL Burst Mode
 - Rx_SD LVTTTL
- BER 10^{-12} (PRBS = 2⁷-1)
- RoHS compliance option

LTB3421 2X5 SFF Interface

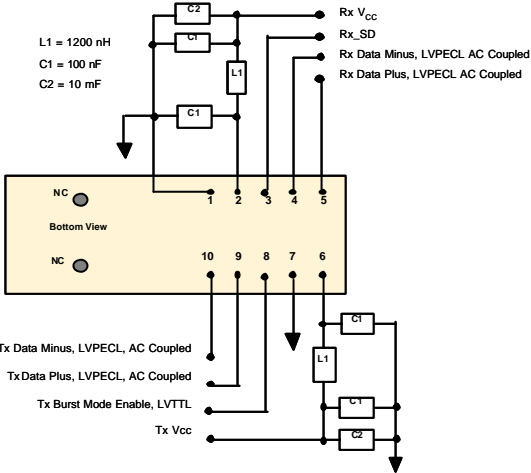

Recommended Operating Conditions					
Parameter	Symbol	Min	Typ	Max	Units
Ambient Operating Temperature	T _{amb}	-40	25	+85	°C
DC Supply Voltage	V _{CC}	3.135	3.3	3.465	Volts
Module Supply Current	I _{IN}	-	200	250	mA
Module Power Dissipation	P _D	-	660	825	mW
Signaling Speed +/- 100 ppm	S	-	1.25	-	GBd
Useful Reach (16:1 Split)	D	-	20	-	km
Useful Reach (32:1 Split)	D	-	10	-	km
Tx_DIS ON to OFF Burs Mode	t _{OFF}	-	-	64	ns
Tx_DIS OFF to ON Burst Mode	t _{ON}	-	-	64	ns

Ordering Information						
Part Number	Package Option(X)		Temperature Option(Y)		RoHS Option(Z)	
LTB3421 XYZ	A	Pigtail, no connector	C	Commercial	+	RoHS compliance
	B	Pigtail, Pigtail with SC/APC	E	Extended		
	C	Pigtail, Pigtail with SC/PC	H	Industrial		



LTB3421 1250 Mb/sec PX-20 P2MP ONU

Burst Mode SFF E-PON Transceiver with SD

Absolute Maximum Ratings					
Parameter	Symbol	Min	Max	Units	Notes
Storage Temperature	T _{stg}	-40	+85	°C	Exceeding the Absolute Maximum Ratings may cause irreversible damage to the device.
Operating Temperature	T _O	-40	+85	°C	
Relative Humidity - Storage	RH _S	0	95	%	
Relative Humidity - Operating	RH _O	0	85	%	The device is not intended to be operated under the condition of simultaneous Absolute Maximum Ratings, a condition which may cause irreversible damage to the device.
DC Supply Voltage	V _{CC}	0	3.6	V	
Soldering Temperature	T _{slid}	0	260	°C	
Soldering Duration	t _{slid}	0	10	sec	

Absolute Maximum Ratings: Control Function Logic Levels					
TX_DISABLE (HIGH)	Tx_DIS _H	-	VCC+0.5	V	LVTTTL
Tx_DISABLE (LOW)	Tx_DIS _L	-	0	V	LVTTTL
Rx_SIGNAL DETECT (HIGH)	SD _H	-	VCC+0.5	V	
Rx_SIGNAL DETECT (LOW)	SD _L	-	0	V	

Transmitter Electrical Specifications						
Parameter	Symbol	Min	Typ	Max	Unit	Conditions / Notes
Tx DC Supply Current	I _{CC}	-	-	150	mA	
Tx_Data Differential Input Voltage	V _{IH-VIL}	300	-	2000	mV p-p	LVPECL Tx_DATA Electrical Signal
Tx_DIS = HIGH (Transmitter OFF)	V _{OH}	2.4	-	3.3	V	LVTTTL
Tx_DIS = LOW (Transmitter ON)	V _{OL}	0	-	0.8	V	LVTTTL

Receiver Electrical Specifications						
Rx DC Supply Current	I _{RX}	-	-	125	mA	
Rx_Data Differential Output Voltage	V _{IH-VIL}	600	-	1900	mV p-p	
Rx_Data Output Rise / Fall Time	t _r / t _f	-	150	260	ps	20% to 80%
Rx_SD = HIGH (Receiver ON)	V _{OH}	2.4	-	3.3	V	LVTTTL CW Mode
Rx_SD = LOW (Receiver OFF)	V _{OL}	0	-		V	LVTTTL CW Mode

LTB3421 Block Diagram

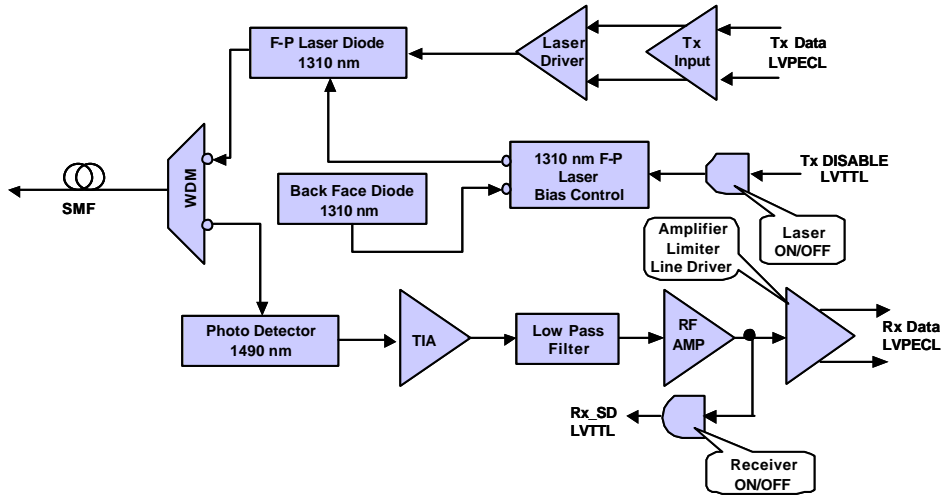



LTB3421 1250 Mb/sec PX-20 P2MP ONU

Burst Mode SFF E-PON Transceiver with SD

Transmitter Optical Specification						
Parameter	Symbol	Min	Typ	Max	Units	Conditions / Notes
Transmitter Type		1310 nm F-P Burst Mode				
Average Output Power (9/125 μ SMF)	P _{out}	-1	-	4.0	dBm	
Optical Output with Tx OFF	P _{out}	-	-	-45	dBm	
OMA Launch Power	P _{out}	-0.22	-	-	dBm	
	P _{out}	0.95	-	-	mW	
Optical Rise and Fall Time	t _r / t _f	-	150	260	ps	20% to 80%
Tx Wavelength	λ	1270	1310	1350	nm	
Spectral Line Width	$\Delta\lambda$	-	-	2.5	nm	IEEE 802.3ah Compliant
Extinction Ratio	ER	9	-	-	dB	
Relative Intensity Noise	RIN	-	-	-115	dB/Hz	
Optical Return Loss	RL	-	-	15	dB	
Total Jitter	T _j	-	-	0.2	UI	
Optical Cross Talk	C _{RT}	-	40	-	dB	
Transmit Reflectance	RFL	-	-	-12	dB	

Receiver Optical Specifications						
Parameter	Symbol	Min	Typ	Max	Units	Conditions / Notes
Receiver Type		1490 nm P-I-N/TIA CW Mode				With 1550nm/1650nm block filter
Optical Signal Indicator		Signal Detect				See Page 5
Wavelength	λ	1480	1490	1500	nm	
Received Optical Power	P _{in}	-26	-	-3	dBm	BER<10 ⁻¹² , 1250 Mb/s, PRBS 2 ⁷ -1 ER=10
Maximum Input Optical Power	P _{in(max)}	-	-	4	dBm	Damage Threshold
OMA Receiver Sensitivity	P _{in}	-	-	-23.2	dBm	
	P _{in}	-	-	5	μ W	
Receiver Reflectance	RFL	-	-	-12	dB	
Stressed Receiver Sensitivity	P _{in}	-	-	-22.1	dBm	
OMA Stressed Receiver Sensitivity	P _{in}	-	-	-21.3	dBm	
	P _{in}	-	-	7.4	μ W	
Vertical Eye Closure Penalty	VEP	1.5	-	-	dB	
Rx_SD Assert	P _a	-42	-	-26	dBm	
Rx_SD Deassert	P _d	-42	-	-26	dBm	
Rx_SD Hysteresis	P _{hy}	0.5	-	10	dB	



LTB3421 1250 Mb/sec PX-20 P2MP ONU Burst Mode SFF E-PON Transceiver with SD

Eye Safety

The transceiver is a Class 1 eye-safe device according to FDA 21CFR1040.10 and 1040.11, IEC 60825-1 and IEC 60825-2.

conform to product safety requirements including UL1950, CSA 22.2, and IEC 60950, and has been designed to meet the flammability requirements of UL94.

Electromagnetic Interference (EMI), Immunity and Product Safety

The transceiver is ESD safe (electrical pins) when tested according to MIL-STD-883, Method 3015.4 and ESD safe (optical connector) when tested according to IEC 61000-4-2. The device is immune to strong RF fields when tested in accordance with IEC 61000-4-3. The device complies with (US) FCC, Part 15, Subpart J; (Europe) CENELEC EN 55022; (Canada) Class B (CISPR22A); and (Japan) VCCI Class 1. The device has been designed to

Notice

The factory has made all adjustments to this device prior to shipment. No adjustments or modifications to the device are required or permitted. Any adjustment, modification or tampering of the device voids the product warranty. The US Food and Drug Administration may consider that any adjustment or modification to this device is an act of manufacturing and therefore will require that the device be recertified in accordance with 21 CFR 1040.10 .